



BULLETIN

892-0000010-B OM
Operation manual

Quantity of sheets Sheet

GROUND: VK 800-3496-07 dd. 29.10.24

| | | |
|---------------------------|----------------|--------------------|
| Bulletin 3-2025 | TRACTOR MODELS | 892 / 892.2 |
|---------------------------|----------------|--------------------|

Annotation

This operation bulletin contains the following information:

- rules for operating the air conditioner, maintenance, possible air conditioner malfunctions and instructions for their elimination;
- names and brands of fuels and lubricants used during operation and maintenance of the air conditioner, indicating their quantity and frequency;
- a maintenance operation has been introduced to replace the filter cartridges of the cabin ventilation and heating system.

Content of changes

The following changes shall be made to subsection 1.3 "Tractor composition":

The information available:

The cabin is one-seated with a protective rigid framework, having thermal, noise and vibration insulation, equipped with a sprung seat adjustable for operator's height and weight, with rear-view mirrors, with a sun visor, with electrical wipers for front and rear screens, with a front screen washer, a roof lamp and a place to install a radio set, with a system of heating and ventilation (upon request – with a ventilation system only).

Shall be replaced with:

The cabin is one-seated with a protective rigid framework, having thermal, noise and vibration insulation, equipped with a sprung seat adjustable for operator's height and weight, with rear-view mirrors, with a sun visor, with electrical wipers for front and rear screens, with a front screen washer, a roof lamp and a place to install a radio set, with a system of heating and ventilation (upon request – with a ventilation system or air conditioner).

The following entry shall be made to subsection 2.1 "Layout of controls and instruments of the tractor":

A fan or an air conditioner may be installed instead of the fan-heater.

The following changes shall be made to subsection 2.17 "Electrical fuses":

1. The legend text of picture 2.17.2 of clause 2.17.2 "Fuses of dashboard with a castable panel" shall be changed as follows:

The information available:

10 – fuse for powering the electric motor of the fan-heater with a rating of 25 A (when the fan-heater 80-8101720 is installed, this fuse is not in use);

Shall be replaced with:

10 – fuse for powering the electric motor of the fan-heater with a rating of 25 A (when the fan-heater 80-8101720 is installed, this fuse is not in use). Fuse for powering the air conditioning, ventilation and heating system when the A/C is installed.

2. Table 2.17.1 of clause 2.17.3 "Fuses of dashboard with a molded panel" shall be changed as follows:

The information available:

| Number in figure 2.17.4 | Rated current | Name of protected circuit |
|-------------------------|---------------|---|
| 10 | 25 A | Powering the fan-heater (when the fan-heater 80-8101720 is installed, this fuse is not in use); |

Shall be replaced with:

| Number in figure 2.17.4 | Rated current | Name of protected circuit |
|-------------------------|---------------|--|
| 10 | 25 A | Powering the fan-heater (when the fan-heater 80-8101720 is installed, this fuse is not in use). Powering the air conditioning, ventilation and heating system when the A/C is installed |

Subsection 2.27 "A/C control" shall be introduced in section 2 "Controls and instruments":

2.27 A/C control

2.27.1 A/C control in conditioning mode

Upon request, an air conditioner can be installed on your tractor instead of a fan-heater.

On the air conditioner control panel there is flow control 1 (Figure 2.27.1) and air conditioner switch 2.

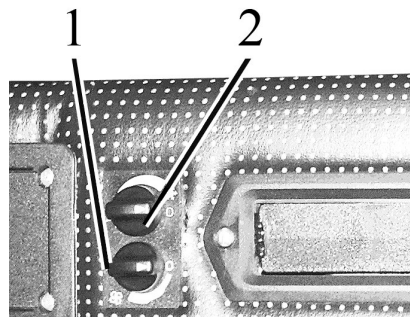

1 – air flow control;
2 – air conditioner switch and temperature adjuster

Figure 2.27.1 – A/C control unit

With the help of air flow control 1 you can change air flow by changing fan speed. Switch 2 allows to change temperature of cold and dry air coming out from deflectors 2 (Figure 2.27.2) in the conditioning mode.

ATTENTION: THE AIR CONDITIONER CAN BE TURNED ON AND OPERATE ONLY WITH THE ENGINE RUNNING!

To switch on the air conditioner it is required to do the following:

- turn switch 2 (figure 2.27.1) clockwise by 180° until the blue scale begins;
- then turn control 1 to one of the three marked positions (the fan rotor has three rotation speeds). After 3-5 minutes adjust the necessary temperature in the cab with switch 2;
- it is possible to adjust a mixture of outer air and recirculation air with recirculation shutters, if installed;

To switch off the air conditioner, turn air flow switch 1 (figure 2.27.1) and A/C switch 2 counterclockwise against the stop into position 0.

ATTENTION: MAKE SURE THE AIR CONDITIONER IS SWITCHED OFF BEFORE STOPPING THE ENGINE!

ATTENTION: WHEN THE AIR CONDITIONER OPERATES IN THE COOLING MODE, MAKE SURE THE HEATER CONTROL VALVE IS SHUT OFF WITH A HANDLE OF THE HEATER CONTROL VALVE 2 (FIGURE 2.27.2) IN ORDER TO PREVENT THE SYSTEMS OF HEATING AND COOLING FROM OPERATING SIMULTANEOUSLY!

2.27.2 Air conditioner control in heating mode

ATTENTION: FILLING THE ENGINE COOLING SYSTEM SHALL BE CARRIED OUT ONLY WITH LOW-FREEZING LIQUID SPECIFIED IN SUBSECTION 6.7 "FILLING AND LUBRICATION OF THE TRACTOR WITH FUEL AND LUBRICATION MATERIALS"!

- To set the air conditioner in the heating mode, do the following:
- start the engine and let the engine run at medium speed without opening the heater control valve to reach coolant temperature from 70 to 80°C;
 - then open the heater control valve by turning handle 2 (Figure 2.27.2) counterclockwise against the stop;
 - check and, if necessary, top up the expansion tank with coolant to reach the upper edge of the expansion tank fastening clamp;
 - turn on the fan heater with the help of air flow control 1 (figure 2.27.1). Within 1-5 minutes warm air shall start coming into the cab, which demonstrates heating system workability;
 - to quickly warm up the cabin, open the recirculation shutters, if installed.

ATTENTION: WHEN OPERATING IN THE HEATING MODE, A/C SWITCH 2 (FIGURE 2.27.1) SHALL BE COMPLETELY OFF TO PREVENT THE AIR COOLING SYSTEM AND THE AIR HEATING SYSTEM FROM OPERATING SIMULTANEOUSLY!

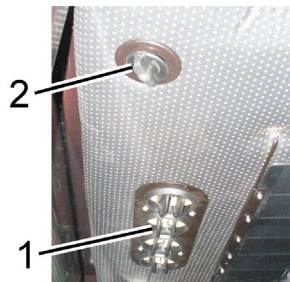

1 – deflectors; 2 – handle of heater control valve
Figure 2.27.2 – Heater control valve assembly

Note – The rules for draining the coolant from the heating and air conditioning system are given in subsection 2.4 “Cab heater and fan control”.

2.27.3 Cab ventilation

During the air conditioner operation in the cooling and heating modes, the cab ventilation is executed simultaneously. To make the air conditioner operate only in the ventilation mode it is necessary to close the heater control valve, set switch 2 (figure 2.27.1.) in position “0” and air flow control 1 in any of three marked positions.

The following changes shall be made to subsection 4.2.5 “Engine stop”:

The information available:

- shift the control handles for the hydraulic lift linkage distributor into neutral position;
- turn off the fan heater;
- pull the engine stop handle;

Shall be replaced with:

- shift the control handles for the hydraulic lift linkage distributor into neutral position;
- turn off the fan heater or the A/C;
- pull the engine stop handle;

The following servicing operations shall be introduced in table 6.3.1 of subsection 6.3 "Maintenance procedure": 6a "Check fastening of A/C hoses. Check/clean drain tubes of air conditioner condenser", 12a "Check/clean A/C condenser", 12b "Check/adjust tension of A/C compressor drive belt", 58a "Change filter cartridges of cab ventilation and heating system", 61a "Perform air conditioning system maintenance" along with notes:

Table 6.3.1

| Operation No | Operation description | Periodicity, h | | | | | |
|---------------------|--|----------------|-----|-----|-----|------|------|
| | | 8-10 | 125 | 250 | 500 | 1000 | 2000 |
| 6 | Check condition of electrical cables in the engine compartment | X | | | | | |
| 6a ⁸⁾ | Check fastening of A/C hoses. Check/clean drain tubes of air conditioner condenser | X | | | | | |
| 7 | Check/clean engine water radiator | X | | | | | |
| 12 | Check level and condition of oil in the engine air cleaner pan | | X | | | | |
| 12a ⁸⁾⁹⁾ | Check/clean A/C condenser | | X | | | | |
| 12b ⁸⁾ | Check/adjust tension of A/C compressor drive belt | | X | | | | |
| 13 ²⁾ | Check oil level in housings of upper bevel pairs of the FDA with bevel wheel gear groups | | X | | | | |

Table 6.3.1 finished

| Operation No | Operation description | Periodicity, h | | | | | |
|-------------------|--|---|-----|-----|-----|------|------|
| | | 8-10 | 125 | 250 | 500 | 1000 | 2000 |
| 58 | Flush engine cooling system and replace coolant | | | | | | X |
| 58a | Change filter cartridges of cab ventilation and heating system | | | | | | X |
| 61 | Check/adjust fuel injection advance angle | | | | | | X |
| 61a ⁸⁾ | Perform air conditioning system maintenance | In every 800 hours of operation but not less than once a year | | | | | |

⁷⁾ Operation is performed on geared lifting rods only.

⁸⁾ The operation is performed if the tractor is equipped with A/C.

⁹⁾ If the tractor is operated in difficult operating conditions and in very dusty conditions, the operation must be performed every 10 hours of operation, i.e. every shift.

Clause 6.4.1.7a "Operation 6a. Check of fastening of A/C hoses. Check/cleaning of drain tubes of air conditioner condenser" shall be added to subsection 6.4.1 "Maintenance on a shift basis (SBMS) in every 8 – 10 hours of operation or per shift":

6.4.1.7a Operation 6a. Check of fastening of A/C hoses. Check/cleaning of drain tubes of air conditioner condenser

The operation is performed on a tractor with an air conditioner installed instead of a fan-heater.

Carry out visual inspection of air conditioner hose fastenings. Air conditioner hoses shall be properly secured with binding clamps. The hoses must not be in contact with moving parts of the tractor.

The tractor is equipped with two drainage tubes, which come out of the front posts of the cab (one tube for each side) (figure 6.4.3a).

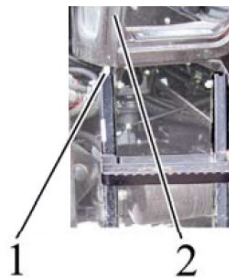

1 – drain tube; 2 – front post of the cab.

Figure 6.4.3a – Location of drain tube outlets

A sign of a clean drain tube is water dripping from the drain tube outlets when the air conditioner is running in hot weather. If water does not drip from the outlets of the drain tubes when the air conditioner is operating in hot weather, it is necessary to blow the drain tubes with compressed air.

The upper outlets of the drain tubes of blue color are located in the upper compartment of the cabin to the right and left of the heater-cooler. To access the upper outlets of the drain tubes, do the following:

- dismantle heater valve handle 3 by unscrewing a screw attaching the handle to panel 4;
- remove two caps 2 from panel 4 (figure 6.4.3b);
- unscrew bolts 1;
- open panel 4.

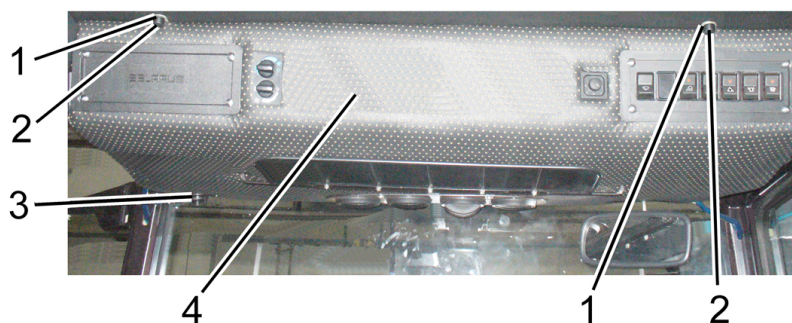

1 – bolt; 2 – cap; 3 – heater valve handle; 4 – panel of the upper cabin compartment.

Figure 6.4.3b – Opening the upper compartment

Disconnect drain tubes 1 (figure 6.4.3c) from outlets 2 of heater-cooler 3, blow the tubes with compressed air, reconnect them to outlets 2 of heater-cooler 3.

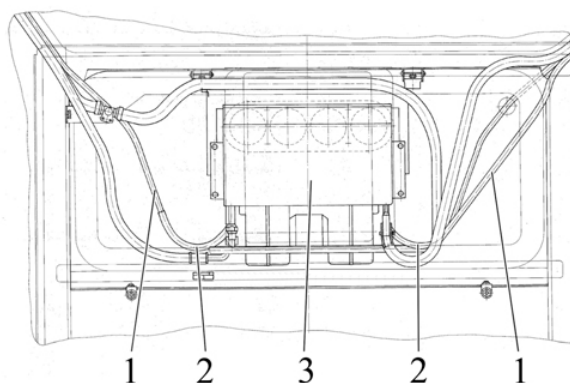

1 – drain tube; 2 – outlet of heater-cooler; 3 – heater-cooler.

Figure 6.4.3c – Upper compartment

Put the panel of the cabin upper compartment back in place, secure it with two bolts, mount the caps and the handle of the heater valve. Tighten the screw attaching the handle to the panel of the cabin upper compartment.

Clauses 6.4.2.4a "Operation 12a. Check/cleaning of A/C condenser", 6.4.2.4b "Operation 12b. Check/adjustment of tension of A/C compressor drive belt" shall be added to subsection 6.4.2 "Maintenance services in every 125 hours of operation":

6.4.2.4a Operation 12a. Check/cleaning of A/C condenser

The operation is performed on a tractor with a pre-ordered air conditioner installed instead of a fan-heater.

Check the cleanliness of the condenser core. If it is clogged, it is necessary to clean the condenser with compressed air. With the hood open, direct air flow perpendicular to the plane of the condenser from top to bottom. Jammed ribs must be straightened with a special comb or plastic (wooden) plate. In case of severe contamination of the condenser, wash it with hot water under a pressure of not more than 0.2 MPa and blow it with compressed air. It is necessary to clean the cores of the radiator both from the side of the hood and from the side of the engine fan.

DO NOT USE AGGRESSIVE DETERGENTS.

ATTENTION: WHEN OPERATING THE TRACTOR IN HARD CONDITIONS AND IN HIGH DUST, THIS OPERATION MUST BE CARRIED OUT AFTER EVERY 8-10 HOURS OF WORK, I.E. EVERY SHIFT!

6.4.2.4b Operation 12b. Check/adjustment of tension of A/C compressor drive belt

The operation is performed on a tractor with an air conditioner installed instead of a fan-heater.

1. Checking of tension of A/C compressor drive belt:

The tension of A/C compressor drive belt 1 (figure 6.4.3d) is considered normal if the deflection of its branch of engine crankshaft pulley - compressor pulley, measured in the middle, stays in the range from 4 to 6 mm, as you apply force of $(39 + 2,0)$ N at right angle to the branch middle.

If this condition is not met, it is necessary to adjust the tension of the A/C compressor drive belt.

2. Adjustment of tension of the A/C compressor drive belt:

Tensional adjustment of belt 1 (figure 6.4.3d) shall be carried out by turning compressor 2 on rotational axis A and tightening threaded connection B in the slot of sector C. After adjustment, belt deflection in response to a force of $(39+2.0)$ N applied at right angle to the middle of the branch shall be within 4 to 6 mm.

Before adjusting the belt tension, it is recommended to loosen the threaded connection B. After adjustment, tighten the threaded connection B with a torque of 40 to 50 Nm.

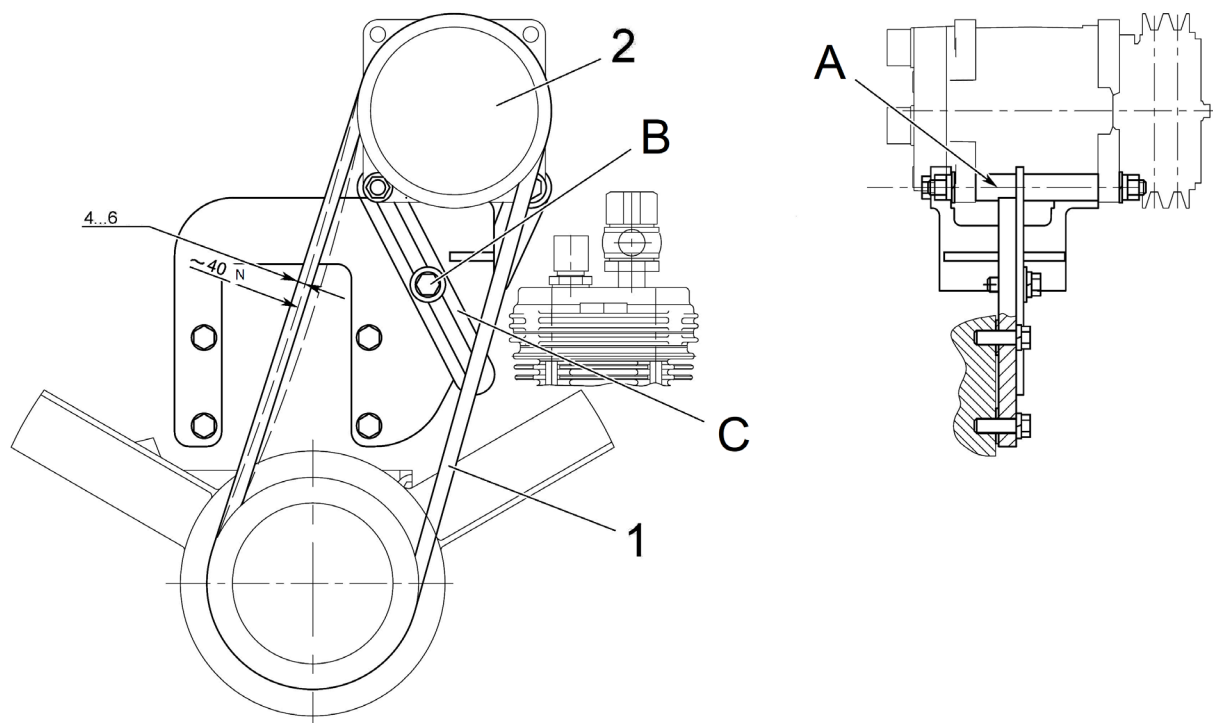

1 - belt; 2 - A/C compressor

Figure 6.4.3d - Adjustment of tension of A/C compressor drive belt

Clause 6.4.6.1a "Operation 58a. Change of filter cartridges of cab ventilation and heating system" shall be added to subsection 6.4.6 "Maintenance service in every 2000 hours of operation":

6.4.6.1a Operation 58a. Change of filter cartridges of cab ventilation and heating system

Change the filter cartridges of the cab ventilation and heating system. The procedure for removing and installing the filter cartridges on the tractor is given in clause 6.4.2.11 "Operation 19. Cleaning of filter cartridges of the filter for cab ventilation and heating system"

Subsection 6.4.6a "Maintenance that does not coincide with the timing of MS-1, 2MS-1, MS-2, MS-3 and special MS" shall be added to subsection 6.4 "Scheduled maintenance servicing operations". Clause 6.4.6a.1 "Operation 61a. Air conditioning system maintenance" shall be added to subsection 6.4.6a:

6.4.6a.1 Operation 61a. Air conditioning system maintenance

Note - This operation is performed when the tractor is equipped with the air conditioner instead of the fan heater.

The operation is performed every 800 hours of tractor running or once a year, whichever comes first.

During the maintenance of the air conditioning system, it is necessary to do the following:

- pump out the used cooling gas and oil from the air conditioning system;
- replace the filter-dryer of the air conditioning system;
- check the air conditioning system for leaks;
- pump fresh cooling gas and oil into the air conditioning system;
- check the operability of the air conditioning system by changing the pressure in the high and low pressure circuits of the air conditioning system.

ATTENTION: TO CARRY OUT SERVICING OF THE AIR CONDITIONING SYSTEM, YOU MUST CONTACT A SPECIALIZED SERVICE STATION. AIR CONDITIONING SYSTEM SERVICING IS CARRIED OUT ONLY USING SPECIAL EQUIPMENT!

The following entries shall be introduced in table 6.7.1 of subsection 6.7 "Filling and lubrication of the tractor with fuel and lubrication materials":

| | | | | | | | | | |
|------|-------------------------|---|---------------------|---------------|---------------|---------------|---------------|------------------------------------|---|
| 2.12 | A/C compressor | 1 | Oil PAG 46 | Not available | Not available | Not available | (0,06 ±0,001) | 800, but not less than once a year | Also in some kinds of repair of conditioning system |
| 4.2 | Air conditioning system | 2 | Cooling agent R134a | Not available | Not available | Not available | 1,6±0,02 | 800, but not less than once a year | Also in some kinds of repair of conditioning system |

Subsection 7.12 "Possible failures of cab ventilation, heating and air-conditioning systems and guidelines for troubleshooting" shall be introduced instead of subsection 7.12 "Possible failures of air-conditioning and cab heating systems and guidelines for troubleshooting":

7.12 Possible failures of cab ventilation, heating and air-conditioning systems and guidelines for troubleshooting

List of possible failures of air-conditioning, ventilation and heating systems of the cabin and guidelines for troubleshooting are shown in Tables 7.12.1 and 7.12.2.

Table 7.12.1 – Possible failures of cab heating systems and guidelines for troubleshooting

| Defect, external manifestation, cause | Troubleshooting |
|---|--|
| Warm air is not supplied inside cabin | |
| Cooling fluid doesn't circulate through heating unit: - heater valve is shut; - heater fan doesn't function | Open heater valve; Eliminate fan failure, check electric circuit of fan actuation according to the electrical equipment diagram |

Table 7.12.2 – Possible failures of air conditioning system and guidelines for troubleshooting

| Defect, external manifestation, cause | Troubleshooting |
|---|--|
| Compressor electromagnetic coupling fails to respond (no metallic click as you turn temperature regulator) | |
| Electrical equipment failure | Using a tester or multimeter, check the operability of the pressure sensor unit, the sensor unit terminals (red and pink wires) should be tested for continuity. Check the serviceability of the electrical circuit connections from the compressor clutch to the air conditioner control panel in accordance with the electrical equipment diagram. |
| Cooling agent leakage occurred | Detect leak point of cooling agent. Only trained personnel using special equipment is allowed to detect the leak point, replace hoses and air conditioner components |
| When A/C is on in cooling mode, warm air comes into cab | |
| Sealing part of heater valve is damaged | Replace the heater valve |

Table 7.12.2 ended.

| Defect, external manifestation, cause | Troubleshooting |
|---|---|
| Condensate or coolant leakage from cab ventilation compartment | |
| Air conditioner drainage tubes are contaminated | Clean the air conditioner drainage tubes, as specified in clause 6.4.1.7a "Check of fastening of A/C hoses. Check/cleaning of drain tubes of air conditioner condenser" |
| Disruption of heater tubes | Replace the climatic unit of the conditioner |
| Non-operable electric motor of conditioner fan | |
| Electric equipment failure | Check the operability of the corresponding fuse located in the switching unit. Replace if it is faulty. If the fuse is sound, check by means of a test-lamp the availability of power supply to the electric motor of the air conditioner fan, when the switch has been turned on, as well as the availability of "ground" on the electric motor. If electric circuits are sound, but there is no power supply to the electric motor of the air conditioner fan, replace the switch. |

WARNING: WEAR PROTECTIVE GLOVES AND GLASSES WHILE DISCONNECTING AND CONNECTING PIPELINES!

WARNING: ANY OPERATIONS RELATED TO DISCONNECTION OF AIR CONDITIONING SYSTEM COMPONENTS SHALL BE CARRIED OUT ONLY BY TRAINED PERSONNEL WITH THE USE OF SPECIAL EQUIPMENT FOR AIR CONDITIONER MAINTENANCE. HIGH PRESSURE IS MAINTAINED EVEN IN THE NON-OPERATING SYSTEM!

WARNING: COOLING AGENT R134A IS NON-TOXIC, NON-COMBUSTIBLE, NOT FORMING EXPLOSIVE MIXTURES. THE COOLING AGENT BOILING TEMPERATURE UNDER NORMAL CONDITIONS IS MINUS 27°C. IN CASE OF SKIN CONTACT WITH LIQUID COOLING AGENT, IT VAPORIZES IMMEDIATELY AND CAN CAUSE OVER-COOLING OF SKIN AREAS!

WARNING: ONLY SPECIALLY TRAINED PERSONNEL IS ALLOWED TO PERFORM REPAIR AND MAINTENANCE OF AIR CONDITIONING SYSTEM COMPONENTS!

In electric circuit diagrams of "Annex A" and "Annex B", variant 5 "With air conditioner" and a corresponding list of components shall be added:

Variant 5
With air conditioner

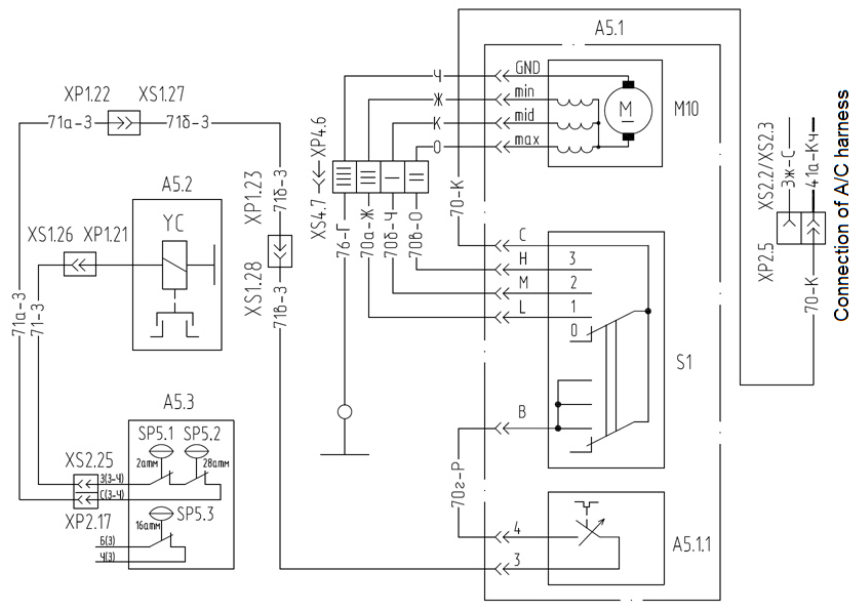

| Designation | Denomination | Q-ty | Note |
|---------------------------|--|------|--|
| A5 | <u>Air conditioner</u> | 1 | |
| A5.1 | <u>Air handling unit</u> | 1 | Part of A/C set |
| A5.11 | Output temperature controller | 1 | |
| M10 | Fan electric motor | 1 | |
| S1 | Fan mode switch | 1 | |
| A5.2 | <u>Compressor-condenser unit</u> | 1 | Part of A/C set |
| YC | Electromagnetic clutch of the compressor | 1 | |
| A5.3 | <u>Pressure sensor unit</u> | 1 | Part of A/C set |
| SP5.1 | Minimum pressure sensor | 1 | 0.2 MPa |
| SP5.2 | Maximum pressure sensor | 1 | 2.8 MPa |
| SP5.3 | Maximum pressure sensor | 1 | 1.6 MPa |
| | <u>Male connectors</u> | | |
| XP1.21...XP1.23 | One-pin receptacle | 3 | |
| XP2.5, XP2.17 | Two-pin receptacle | 2 | |
| XP4.6 | Four-pin receptacle | 1 | |
| | <u>Female connectors</u> | | |
| XS1.26...XS1.28 | One-pin receptacle | 3 | |
| XS2.2 or XS2.3, XS2.17 | Two-pin receptacle | 2 | Receptacle XS2.2 or XS2.3 of roof harness depending on tractor configuration |
| XS4.7 | Four-pin receptacle | 1 | |